

### Overcurrent Sense Resistors

The Micrel MIC5156/7/8 Super LDO™ Regulator Controllers require a moderately low-value current-sensing resistor. Building the resistor from printed-circuit board (PCB) copper is attractive; arbitrary values can be provided inexpensively. The ever-shrinking world of electronic assemblies requires minimizing the physical size of this resistor, which can present a power-dissipation issue that must be resolved to provide a reliable solution. Making the resistor too small could cause excessive heat rise, leading to PCB trace damage or destruction (a fuse rather than a controlled resistor).

A demonstration board is available for evaluating the MIC5158. The circuit is designed to produce a 3.3V, 5A output from a 5V input. The design goal was to occupy as little PCB space as practical, so minimizing sense resistor area was important. In Figure 1 this resistor is shown as  $R_S$ .

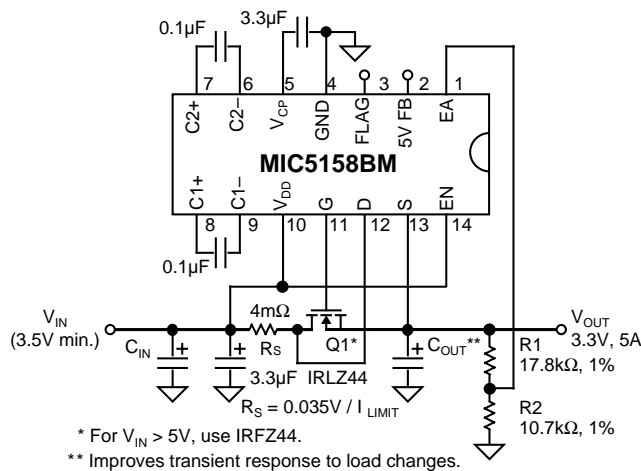

Figure 1. Regulator Circuit Diagram

### Resistor Design Method

Three design equations provide a resistor that occupies the minimum area. This method considers current density as it relates to heat dissipation in a surface layer resistor.

$$(1) \quad \rho_s(T) = \frac{\rho [1 + \alpha (T_A + T_{RISE} - 20)]}{h}$$

where:

- $\rho_s(T)$  = sheet resistance at elevated temp. ( $\Omega/\square$ )
- $\rho = 0.0172$  = copper resistivity at 20°C ( $\Omega \cdot \mu\text{m}$ )
- $\alpha = 0.00393$  = temperature coefficient of  $\rho$  (per °C)

- $T_A$  = ambient temperature (°C)
- $T_{RISE}$  = allowed temperature rise (°C)
- $h$  = copper trace height ( $\mu\text{m}$ , see Table 1).

$$(2) \quad w = \frac{1000 I_{MAX}}{\sqrt{\frac{T_{RISE} + \theta_{SA}}{\rho_s(T)}}}$$

where:

- $w$  = minimum copper resistor trace width (mils)
- $I_{MAX}$  = maximum current for allowed  $T_{RISE}$  (A)
- $T_{RISE}$  = allowed temperature rise (°C)
- $\theta_{SA}$  = resistor thermal resistance ( $^{\circ}\text{C} \cdot \text{in}^2/\text{W}$ )
- $\rho_s(T)$  = sheet resistance at elevated temp. ( $\Omega/\square$ ).
- Note:  $\theta_{SA} \approx 55^{\circ}\text{C} \cdot \text{in}^2/\text{W}$  (see Figure 3).

$$(3) \quad l = \frac{w R}{\rho_s(T)}$$

where:

- $l$  = resistor length (mils)
- $w$  = resistor width (mils)
- $R$  = desired resistance ( $\Omega$ )
- $\rho_s(T)$  = sheet resistance at elevated temp. ( $\Omega/\square$ ).

### Design Example

The 4-m $\Omega$  current-sensing resistor ( $R_S$ ) of Figure 1 is designed as follows: (1) based on copper trace height and an allowed temperature rise for the resistor, calculate the sheet resistance (Equation 1); (2) based on the maximum current the resistor will have to sustain, calculate its minimum trace width (Equation 2); and (3) based on the desired resistance, calculate the required trace length (Equation 3).

#### Calculate Sheet Resistance

This design uses 1 oz/ft<sup>2</sup> weight PCB material, which has a copper thickness (trace height) of 35.6 $\mu\text{m}$ . See Table 1. It was also decided to allow the resistor to produce a 75°C temperature rise, which would place it at 100°C (worst case) when operating in a 25°C ambient environment. Then:

$$\rho_s(T) = \frac{\rho [1 + \alpha (T_A + T_{RISE} - 20)]}{h}$$

$$\rho_s(T) = \frac{0.0172 [1 + 0.00393 (25 + 75 - 20)]}{35.6}$$

$$\rho_s(T) = 635 \times 10^{-6} \Omega = 0.635 \text{ m}\Omega/\square.$$

### Calculate Minimum Trace Width

The design example provides an output current of 5A. Because of resistor tolerance and the current-limit trip-point specification of the MIC5158 (0.028 to 0.042V), a trip-point of 8.75A is chosen. It was also decided to allow for as much as 10A of current during the sustained limiting condition. Then:

$$w = \frac{1000 I_{MAX}}{\sqrt{\frac{T_{RISE} \div \theta_{SA}}{\rho_s(T)}}}$$

$$w = \frac{1000 \times 10}{\sqrt{\frac{75 \div 55}{635 \times 10^{-6}}}}$$

$$w = 215.8 \text{ mils} \approx 216 \text{ mils.}$$

### Calculate Required Trace Length

The length of a 4-mΩ resistor is determined via Equation 3 as follows:

$$l = \frac{w R}{\rho_s(T)}$$

$$l = \frac{216 \times 0.004}{635 \times 10^{-6}}$$

$$l = 1360.6 \text{ mils} \approx 1361 \text{ mils.}$$

### Resistor Layout

To avoid errors caused by voltage drops in the power leads, the resistor should include Kelvin sensing leads. Figure 2 illustrates a layout incorporating Kelvin sensing leads.

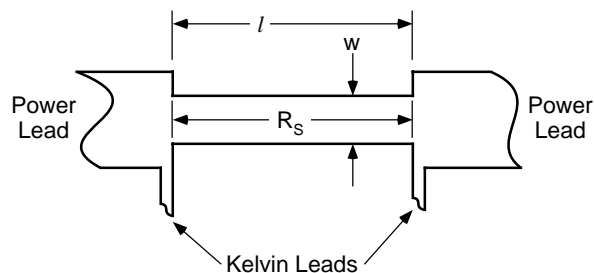

Figure 2. Typical Resistor Layout

### Thermal Considerations

The above equations produce a resistance of the desired value at *elevated temperature*. It is important to consider resistance at temperature because copper has a high temperature coefficient. This design method is appropriate for

current-sensing resistors because their accuracy should be optimized for the current they are intended to sense.

### References

Table 1 and Figure 3 are provided as support and background information. Table 1 provides an input needed for Equation 1 (trace height), and Figure 3 indicates that 1 in<sup>2</sup> (645 mm<sup>2</sup>) of solder-masked copper in still air has a thermal resistance of 55°C/W. Different situations; e.g., internal layers or plated copper, will have different thermal resistances. Other references include:

MIL-STD-275E: *Printed Wiring for Electronic Equipment*.

Application Hint 17: "Calculating P.C. Board Heat Sink Area For Surface Mount Packages," *Micrel 1995 Databook*.

Application Hint 21: "Sense Resistors for the Super LDO™ Regulator," *Micrel 1995 Databook*.

PCB Weight (oz/ft <sup>2</sup> )	Copper Trace Height	
	(mils)	(μm)
1/2	0.7	17.8
1	1.4	35.6
2	2.8	71.1
3	4.2	106.7

Table 1. Copper Trace Heights

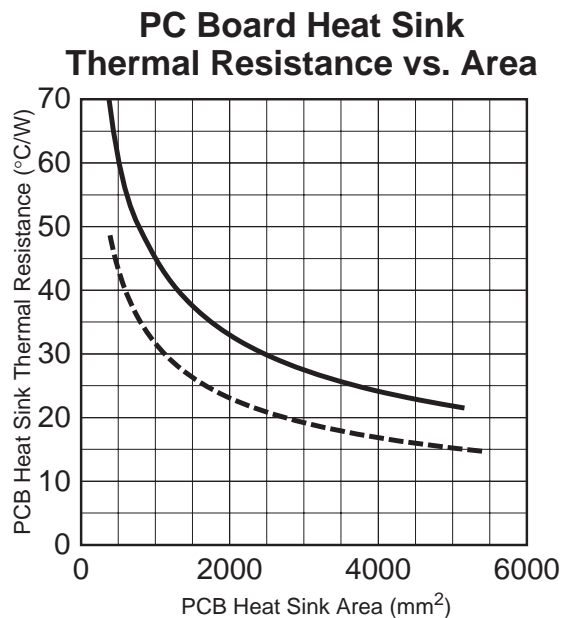

Figure 3. Thermal Resistance of Copper Trace Area